



# Gratings Handrails & Stanchions

Your metal supplier

E-mail: [commercial@bssmoz.com](mailto:commercial@bssmoz.com)  
Website: [www.bssmoz.com](http://www.bssmoz.com)

## Handrails & Stanchions

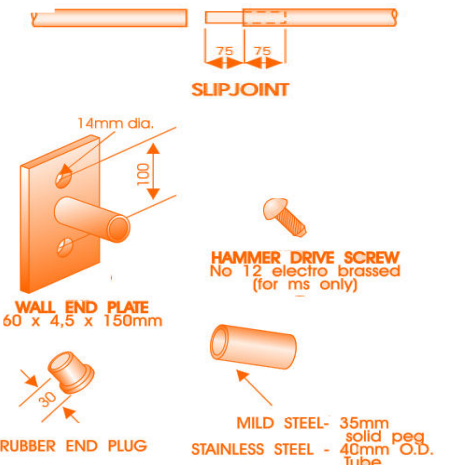
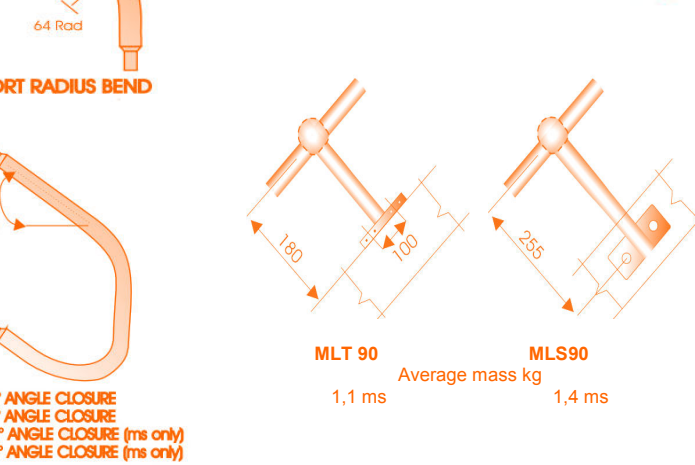
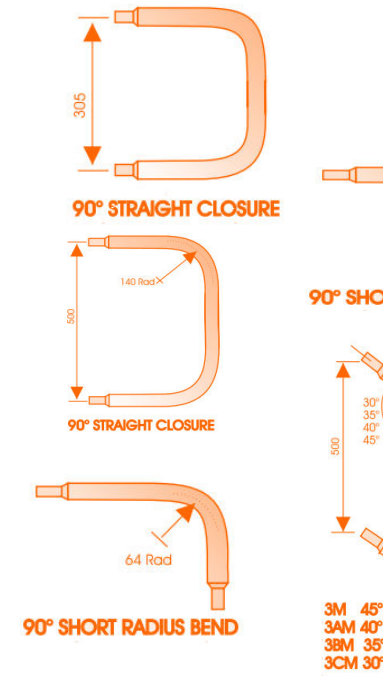
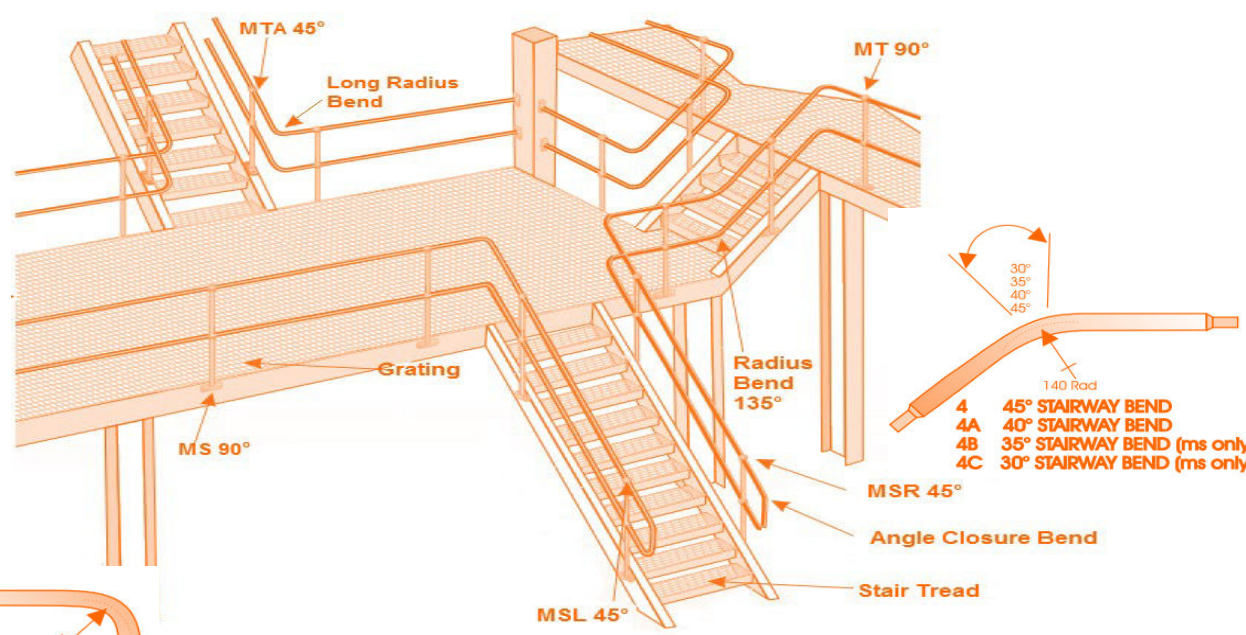
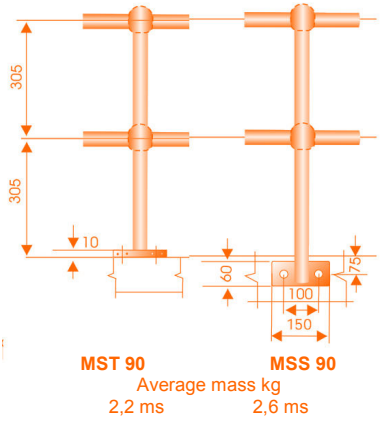
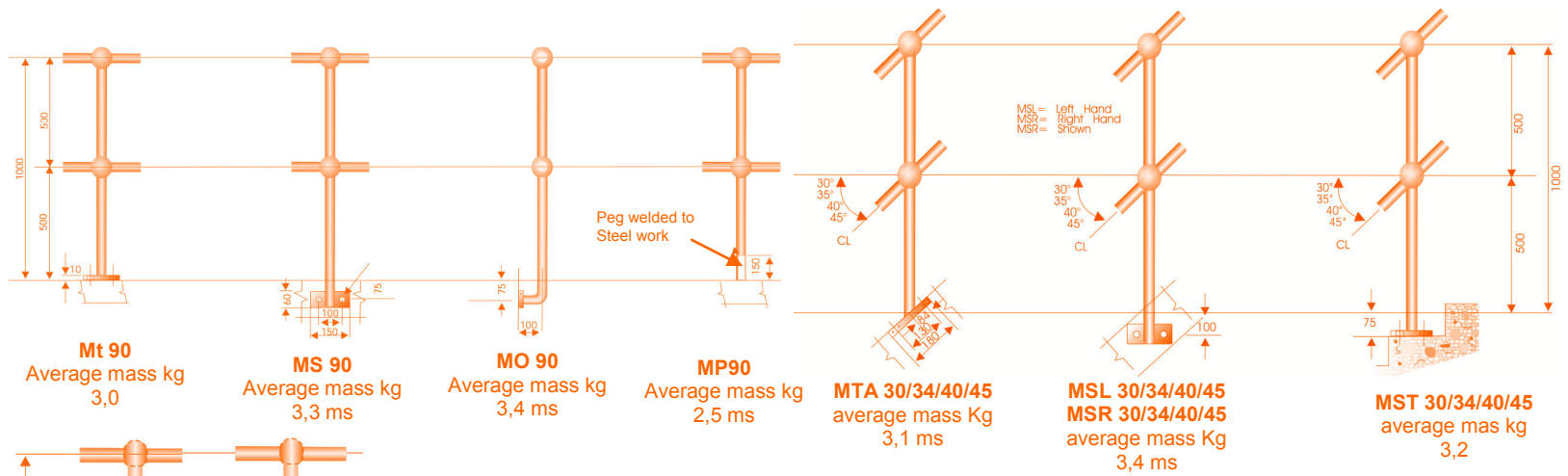

## Gratings

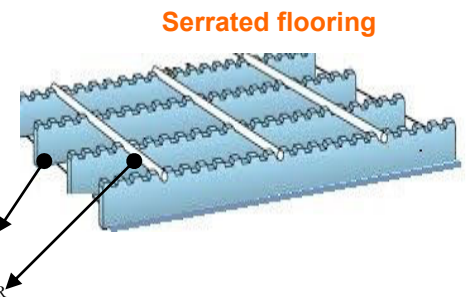
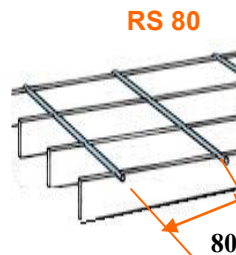
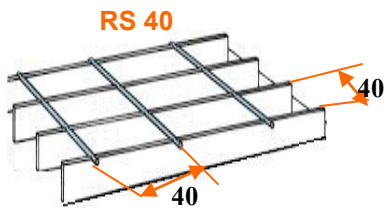

Standard Grating SR 40

| Bearer Size | Panel Size |          | Uncoated Mass kg |
|-------------|------------|----------|------------------|
|             | Length mm  | Width mm |                  |
| 25 x 4.5    | 2400       | 1200     | 86               |
| 20 x 4.5    | 2400       | 1200     | 100              |
| 40 x 4.5    | 2400       | 1200     | 125              |

### GRATING FASTENING METHOD

Saddle Clamp, L - Bracket, Bolt, Nut and washer

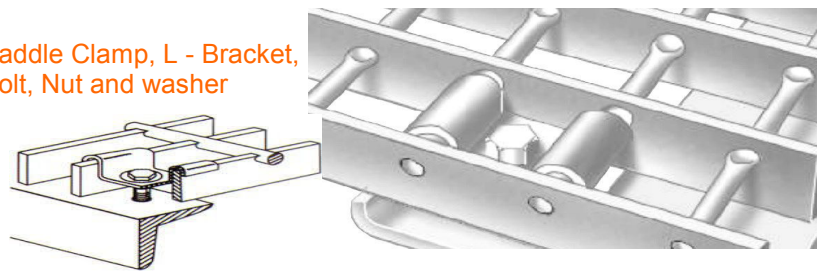

We also supply these non standard type of Gratings

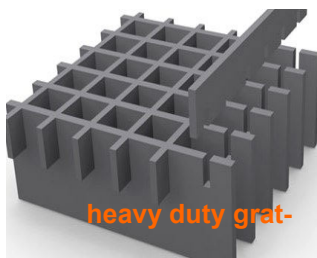

heavy duty grat-

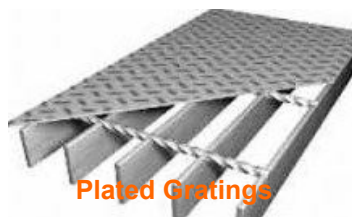

Plated Gratings

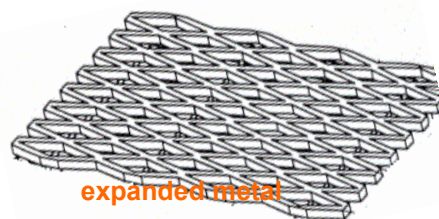

expanded metal

## STAIRTREADS

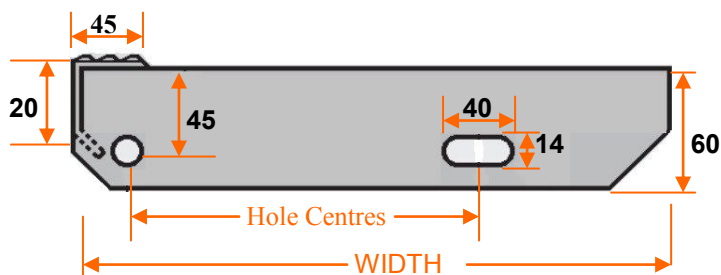

Stair Treads up to 750mm long have 25mm x 4.5mm bars between 751mm and 1000mm the bearer bars are 30mm x 4.5mm.

Tolerance 5mm on width, + 0-22mm on length

Stair Treads in non standard sizes are available on request

### Specifications

| Length (mm) | Width (mm)    | Hole Centres (mm)            | Bearer Bars |
|-------------|---------------|------------------------------|-------------|
| 500         | 205, 245      | 115, 150, 115                | 25 x 4.5    |
| 600         | 200, 245      | 115, 150, 115                | 25 x 4.5    |
| 750         | 205, 245, 285 | 115, 150, 115, 180, 150, 115 | 25 x 4.5    |
| 900         | 205, 245, 285 | 115, 150, 115, 180, 150, 115 | 30 x 4.5    |
| 1000        | 205, 245, 285 | 115, 150, 115, 180, 150, 115 | 30 x 4.5    |